



CLEAN AIR BEGINS WITH US

Solutions for Compressed
Air Treatment

SOLUTION FOR COMPRESSED AIR TREATMENT

COMPRESSED AIR ADSORPTION DRYER

C-HDDN Series

The Problem

Compressed air is an industrial wide used power source. Over the years it became a crucial part of a wide range in industrial processes. However, compressed air after compression is not clean and contains impurities like water, oil, dirt, wear particles and so on. This mixture creates a form of condensate which damages downstream equipments. It also causes high product rejects, high maintenance and costly air leaks in compressed air systems. The use of highly efficient compressed air filters and condensate drains will remove a lot of these impurities and can eliminate most of the problems downstream.

For many applications this is not enough. These applications need an even higher level of compressed air quality. AFE's C-HDDN desiccant dryers will provide this level of air quality at the point where the quality is needed without investing a large amount in centralized purification systems which are often not needed because only certain areas of the production process need that high quality air.

The Solution

The C-HDDN series of compact desiccant air dryers offers users the air quality at the point where it is needed. Utilizing a reliable technology, the C-HDDN dryers provide the security to run the process without interruption and to have safe and reliable operations of downstream machines and air tools.

This series comes with installed pre- and afterfilter, desiccant fill and a reliable PCB controller with indication lights to monitor the operation. The PCB controller is ready build in and only has to be connected to an electrical power source and compressed air inlet/outlet. Optionally available is a dryer run/stop dry contact as well as a load control system for energy savings.

This series of compact desiccant air dryers will meet the requirements of ISO 8573.1 Class 1.2.1 as a standard. Higher quality classes based on request are available.

How does the AFE C-HDDN Desiccant Dryer work?

Two vessels connected in parallel are required for the continuous operation of drying via the adsorption process. Each vessel is filled with desiccants which act as the drying medium. AFE desiccant dryers use high performance molecular sieve which have a long service life at high input temperatures, resulting in very low pressure dew points.

Stage 1:

The drying of compressed air takes place in vessel A and simultaneously, desorption (re-generation of the desiccant) occurs in vessel B. The desorption process in vessel B occurs in a counter flow direction by using a small flow of dry compressed air channeled from the outlet of vessel A. The mode of operation of pressure change desorption corresponds to almost isothermal desorption through partial pressure drop in the adsorbing component by means of pure purge gas.

Stage 2:

Upon completion of the re-generation cycle, re-pressurization takes place in vessel B until both vessels equalize in pressure. At this stage, the vessels are ready to switch over.

Stage 3:

The air from vessel A will purge out and the drying cycle switches to vessel B. Vessel A will now undergo the desorption cycle to re-generate the desiccants.

The entire process will repeat itself to continuously dry the compressed air.

All AFE dryers are installed with coalescing pre-filters and particle after-filters to provide clean and dry compressed air (CDA).

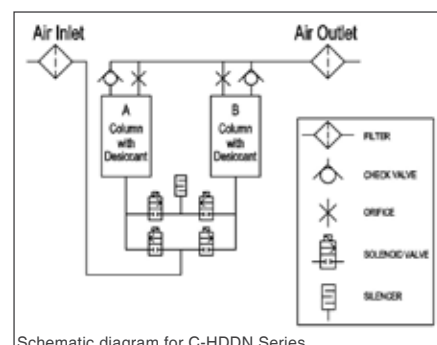

Schematic diagram for C-HDDN Series

Benefits of the C-HDDN series:

- Point of use application:
Air quality at the point where it's needed.
- Simple installation:
Only air in/air out and power to be connected.
- Compact design:
Specially designed for point of use applications,
small footprints.
- Easy maintenance:
Designed for quick parts change with standard
components.
- Universal to install:
Can be either floor or wall mounted.



SOLUTION FOR COMPRESSED AIR TREATMENT

COMPRESSED AIR FILTERS

High efficiency filtration for clean & technically oil-free compressed air.

There are millions of particles in a cubic metre of environmental air and over 80% of these particles are less than 2 micron in size. When this air is compressed to, say 7 bar g, the ratio of contaminants to air also increases 7 fold. This will definitely contribute problems to the compressor system with wear particles, oil vapours and fine aerosols. Inefficient purification can lead to unnecessary high operating and maintenance costs. With today's highly advanced and sensitive pneumatic equipment, an efficient and reliable compressed air filter in conjunction with other compressed air treatment products is necessary to provide years of trouble-free service.

Our engineers in the research and development department ensure that we continuously satisfy the increasing demands of today's sophisticated market with high quality filtration products to ensure clean compressed air is readily available. Airfilter Engineering guarantees you quality, reliability and efficiency in all our products which have been specifically designed to offer you the best solution for your compressed air filtration needs. Our filters are manufactured with either die-cast aluminium or carbon steel housings for wide range of operating pressures and capacities. These filters were designed in accordance with international standards and carry the CE mark, complying with the European Pressure Equipment Directive PED 2014/68/EU.

With over 20 years of experience, Airfilter Engineering offers a comprehensive range of filters with different filtration grades to meet the recommendation of the ISO8573 for different types of users. It has been engineered for low pressure drop, which gives the benefit of minimum energy and maintenance cost. Airfilter Engineering's products are highly effective yet economical to your total business investment. The filters are fully tested for performance, safety and leakage, and treated to prevent surface oxidation.

Why install Compressed Air Filters?

- Reduce production cost
- Reduce production reject rate
- Reduce breakdown of pneumatic system
- Reduce production down time
- Improve production quality
- Improve productivity
- Improve efficiency of compressed air system
- Improve performance of pneumatic system

Why AFE Filter?

- Proven reliable products
- Elements with efficient pleated design
- Quality products at reasonable prices
- Ready stocks, prompt delivery
- Accepted and exported worldwide
- CE marked, complies with European PED 2014/68/EU
- Can be customized to your requirements
- Tested & validated by third party



AFE Filter Series

Airfilter Engineering (AFE) has developed a comprehensive range of filter grades to cater to the requirements of different applications. All our filter media are of pleated design to ensure higher filtration area. Here at AFE, filters and elements can also be custom-made to suit your needs.

AFE Filter Grade P

- For coarse pre-filtration
- Particle removal down to 3 micron

AFE Filter Grade U

- For general filtration
- Particle removal down to 1 micron
- Oil content down to 0.1 mg/m³ at 20°C

AFE Filter Grade H

- For high performance filtration
- Particle removal down to 0.01 micron
- Oil content down to 0.01 mg/m³ at 20°C

AFE Filter Grade S

- For high performance filtration
- Particle removal down to 0.01 micron
- Oil content down to 0.001 mg/m³ at 20°C in conjunction with filter grade H

AFE Filter Grade C

- Activated carbon filter.
- For odour removal. Applicable in oil lubricated compressors.
- For removal of oil content down to 0.003 mg/m³ at 20°C

Differential Pressure Gauge

Aluminium Housing

Automatic Condensate Drain

Manual Drain Valve



ISO - 8573-1: 2010 – Table of Contaminants and Purity Classes

Purity Class	PARTICLES				HUMIDITY AND LIQUID WATER		OIL
	Maximum number of particles per cubic metre as a function of particle size, d			Mass Concentration C	Pressure Dewpoint	Concentration Of Liquid Water, C	Concentration Of Total Oil (Liquid, Aerosol & Vapour)
	0.1 µm < d ≤ 0.5 µm	0.5 µm < d ≤ 1.0 µm	1.0 µm < d ≤ 5.0 µm	mg/m ³	°C	g/m ³	mg/m ³
0	As specified by the equipment user or supplier and more stringent than Class 1						
1	≤ 20 000	≤ 400	≤ 10	-	≤ -70	-	≤ 0.01
2	≤ 400 000	≤ 6 000	≤ 100	-	≤ -40	-	≤ 0.1
3	Not specified	≤ 90 000	≤ 1 000	-	≤ -20	-	≤ 1
4	Not specified	Not specified	≤ 10 000	-	≤ +3	-	≤ 5
5	Not specified	Not specified	≤ 100 000	-	≤ +7	-	-
6	-	-	-	0 < C _p ≤ 5	≤ +10	-	-
7	-	-	-	5 < C _p ≤ 10	-	C _w ≤ 0.5	-
8	-	-	-	-	-	0.5 < C _w ≤ 5	-

The ISO 8573-1 is a key element of the ISO 8573 series of documents and it specifies the various purity classes of compressed air with respect to particles, water and oil.

EXAMPLE OF DESIGNATION: ISO 8573-1:2010 [1:2:1] indicate,

- purity Class 1 for particles
- purity Class 2 for humidity and liquid water
- purity Class 1 for oil

SOLUTION FOR COMPRESSED AIR TREATMENT

WATER SEPARATORS

Centrifugal separation to remove up to 99% of water aerosol in compressed air.



Why should you buy AFE's Water Separator?

- Removes 99% bulk water
- Very low maintenance cost
- Simple and easy to install
- Efficient automatic drain
- Robust aluminium housing



Vortex Generator - Vane
Aerodynamically designed vortex generator vanes for greater efficiency



Vortex Generator - Cone
Conical profile for enhanced vortex effect



Cyclone Arrester
Special profile designed to improve separator efficiency and prevent re-entrainment of separated water.



Automatic Condensate Drain
Efficiently discharge (collected) condensate from the system

For compressed air installations where water is a real problem, Airfilter Engineering's water separators can deal simply and effectively with the problem. Typically, water separators are installed downstream of after coolers, air receivers, refrigeration dryers and at strategic points in pipe work installations. Airfilter Engineering's water separators are designed to remove up to 99% water aerosols in the compressed air at very low maintenance cost. Our water separator applies the centrifugal motion effect to force liquid water out of compressed air. The spinning causes the condensate to merge on the water separator walls and when the condensate gains enough mass it falls to the bottom of the separator bowl where it is stored until it is flushed out of the system by the automatic drain valve.

The water separator comes in aluminium housing with polypropylene mechanism. They are available for operating pressures of up to 16 bar g.

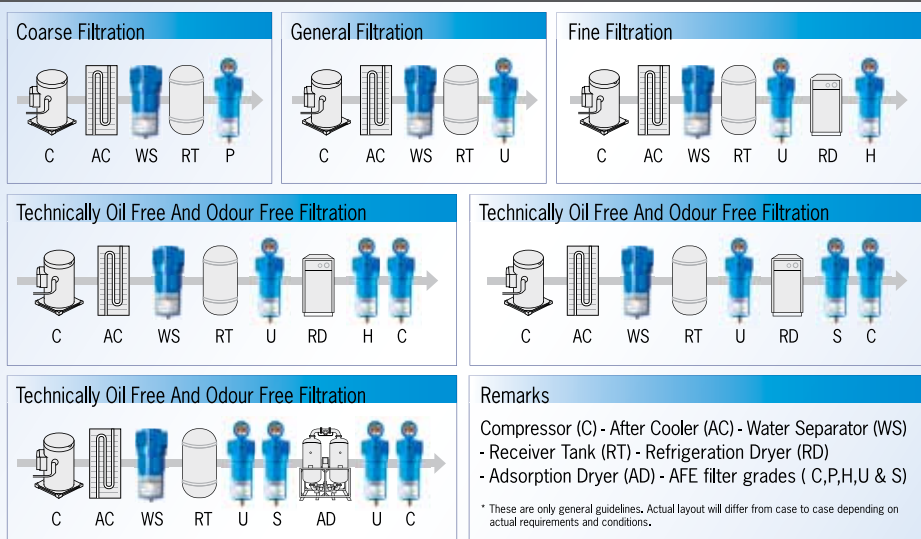

Remarks
Compressor (C) - After Cooler (AC) - Water Separator (WS)
- Receiver Tank (RT) - Refrigeration Dryer (RD)
- Adsorption Dryer (AD) - AFE filter grades (C,P,H,U & S)

* These are only general guidelines. Actual layout will differ from case to case depending on actual requirements and conditions.

COMPATIBLE COMPRESSED AIR FILTER ELEMENTS

Pleated Filter Media, available for most leading brands in the market.

Airfilter Engineering produces a comprehensive range of compatible replacement elements suitable for installation in other competing brands of filters. Every element is built to the same exacting standards at Airfilter Engineering. That means that our compatible elements have been constructed from the same high quality materials that are used for all Airfilter Engineering's products. This, coupled with our pleated design, ensures that performances of our compatible elements are at least equal to or better than the original brands.

Why should you buy AFE Compatible Elements?

- Reliable and efficient pleated media design
- Available for most leading brands in the market
- High quality products at reasonable prices
- Ready stocks available to be shipped worldwide
- Remanufacture or custom build any filter element
- Performance tested and validated by third party



The basic benefits that we can offer with our filter media are:

- higher effective filtration area
- higher dirt holding capacity
- lower pressure drop
- possibility of higher air flow

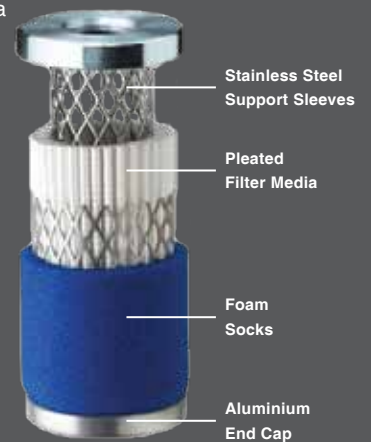

COMPRESSED AIR ACCESSORIES

Airfilter Engineering has available a complete range of accessories to complement the core products.

These include:

- automatic condensate drains
- differential pressure gauges
- differential pressure indicators
- mounting brackets
- connecting kits
- and others...



THE COMPANY

From its humble beginnings in 1993, Airfilter Engineering has grown and continues to grow from strength to strength and is producing products for the treatment of compressed air in its factory in Shah Alam, Malaysia. Today Airfilter Engineering's products are sold mainly through distributors and OEMs in many different countries in Asia, Europe and America.

To provide an even better and faster service to customers in Europe AFE Airfilter Europe GmbH was founded in 2007 and a warehouse and distribution center was set up in Bornheim/Cologne in Germany.

A research and development (R&D) Department was set up in 1995 to ensure that new products are introduced and existing products are continuously updated. Products performance are regularly monitored and improved, with validation of these products by independent third party institute being done periodically. These milestones are testament to Airfilter Engineering's continued commitment to improve and innovate in all aspects of the operations. Since 2002 Airfilter Engineering is certified to the ISO9001 by Lloyds Register Quality Assurance and its products carry the CE mark and comply with the European Pressure Equipment Directive, PED 2014/68/EU.

The goals of Airfilter Engineering are very simple:

- to support the industry in their need for clean compressed air for pneumatic systems, mainly in electronics, semi-conductors, medical / pharmaceutical, chemical, plastic, textile, automobile, food & beverage, furniture and consumer products
- to exceed customer's expectations through high quality products
- continuously improvements to the quality
- excellent customer relationships

Why should you buy from AFE?

- An ISO9001 certified company
- Friendly & efficient service
- Quality & reliable products
- Comprehensive product range
- Products are CE marked
- Products are tested & validated
- Individual product customization
- Fast delivery

Committed to Quality

Quality Assurance

Our company has been audited by Lloyds Register Quality Assurance (LRQA) and awarded the ISO 9001.

International Approval

Our products have been certified by Lloyds Register to be in compliance to the European Pressure Equipment Directive (PED 2014/68/EU) and carry the CE mark.

Tested and Validated

Our products have been tested and validated in accordance to ISO 8573 by a reputable independent institute in Germany. A copy of the certificate is available upon request.

